



INSTALLATION INSTRUCTIONS

Accessory

FRONT FORK BOOT
P/N 08F70-K87-A31

Application

CMX300/A
CMX500/A

Publication No.

MII

Issue Date

March 2020

Honda Dealer: Please give a copy of these instructions to your customer.

PARTS LIST

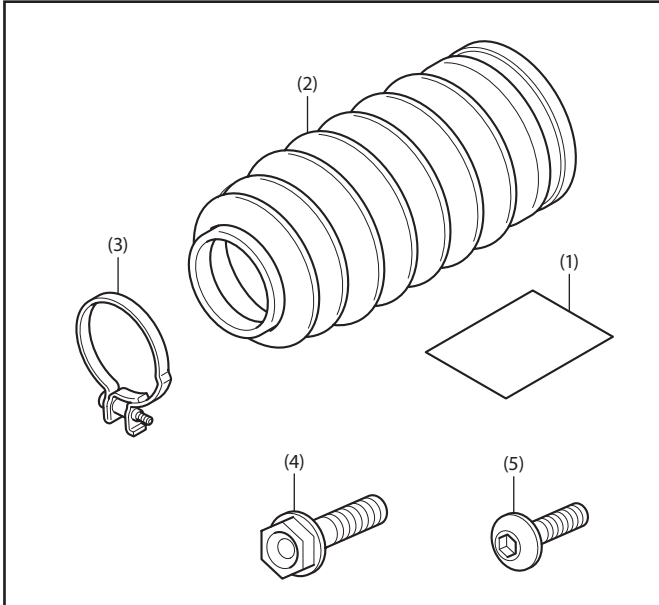

No.	Description	Qty
(1)	URL paper	1
(2)	Front fork boot	2
(3)	Band	2
(4)	Frange bolt (8 x 32)	2
(5)	Socket bolt (6 x 25)	4

TOOLS REQUIRED

Socket (12 mm)

Ratchet

Hex wrench (5 mm)

Phillips® screwdriver

Torque wrench

TORQUE INFORMATION

Refer to the Service Manual for the torque values of the removed parts.

INSTALLATION

▲ CAUTION

- To prevent burns, allow the engine, exhaust system, radiator, etc. to cool before installing the accessory.

NOTE:

- Take care not to damage the painted surfaces of the motorcycle.
- Refer to the Service Manual for the motorcycle, remove the motorcycle parts.
 - Do not suspend the brake caliper assembly from the brake hose.

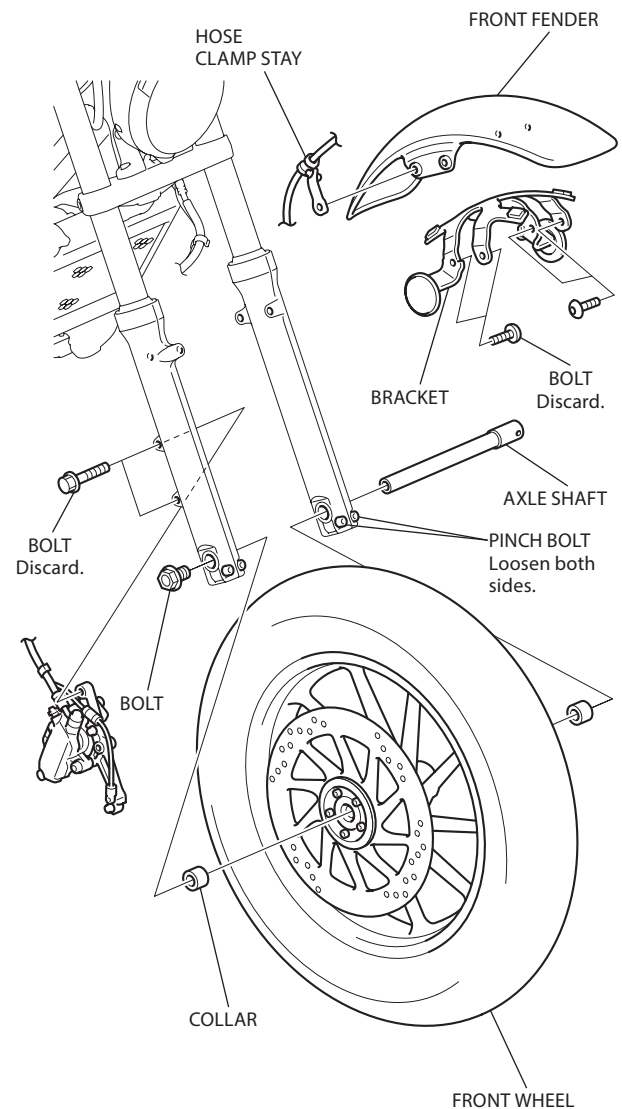

2. Refer to the Service Manual for the motorcycle, remove the motorcycle parts.
 - Repeat on the left side.

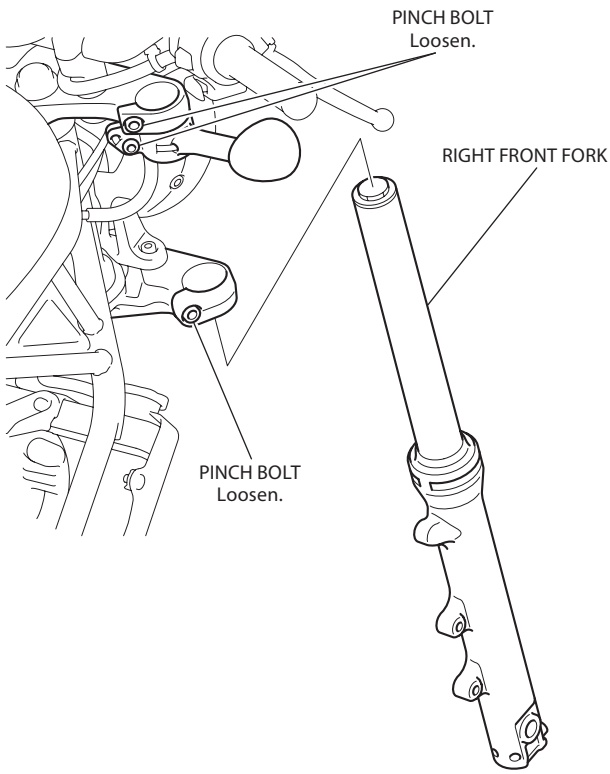

4. Install the removed parts in the reverse order of removal and tighten the loosely installed hardware.
 - Replace the brake caliper bolts and front fender bolts with new ones.
 - Tighten the band screw firmly until the collar is fully seated.

3. Loosely install the front fork boot as shown.
 - Repeat on the left side.

